



# 68G5 3U OpenVPX™ Multifunction I/O & Communications Board

Three I/O and Communications function module slots –  
Over 70 different functions to choose from

## Configure to Customize

The 68G5 is a 3U OpenVPX™ board that can be configured with up to three NAI smart I/O and communication function modules. Ideally suited for rugged Mil-Aero applications, the 68G5 delivers off-the-shelf solutions that accelerate deployment of SWaP-optimized systems in air, land and sea applications.

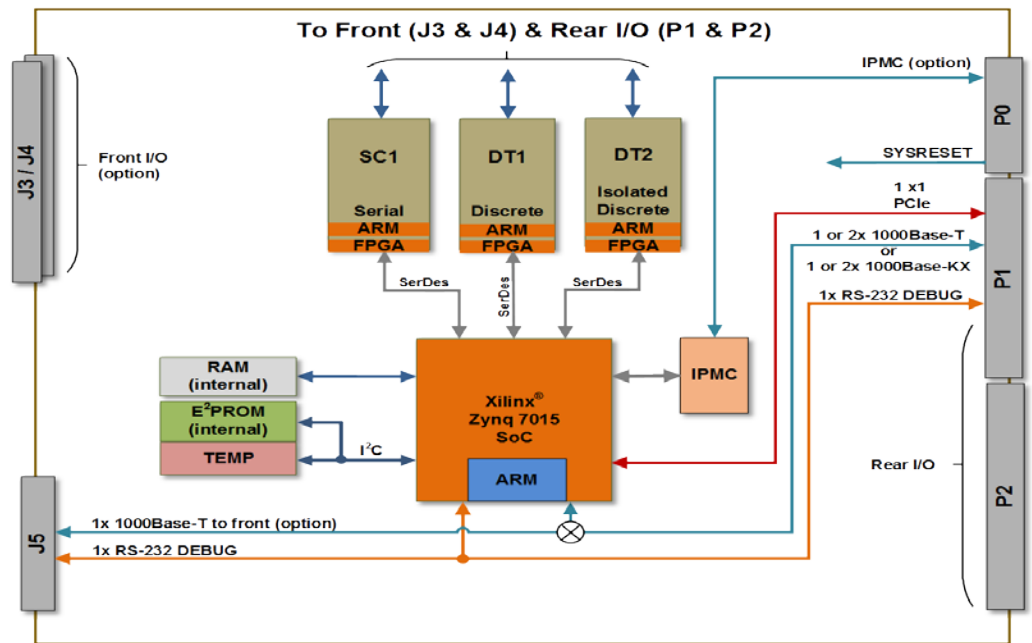

## Features

- Slot profile: SLT3-PER-1U-14.3.3
- Module profile: MOD3-PER-1U-16.3.3-2
- Up to 3 independent smart I/O function modules supported
- Front and/or rear I/O
- Commercial or rugged applications
- PCIe (x1)
- Independent x1 SerDes interface to each function module slot
- 2x 10/100/1000 Base-T Ethernet; 2 to rear or 1 to rear and 1 to front I/O
- Continuous Background Built-in-Test (BIT)
- Intelligent I/O library support included
- COSA® Architecture
- VICTORY Interface Services (Contact factory)
- Operating temp: 0° C to +70° C or Rugged -40° C to +85° C

### Select up to 3 independent functions for your application

I/O		Measurement & Simulation	
<a href="#">A/D</a>	±1.25 VDC to ±100 VDC or 0-25 mA; 16 or 24-Bit; 12 or 16 Ch	<a href="#">Synchro/Resolver-Digital</a>	16-Bit; ±1Arc-Min accuracy; 4 Ch. (Measurement)
<a href="#">D/A</a>	±1.25 VDC to ±80 VDC or ±25 mA to 100 mA; 16-Bit, 4-16 Ch	<a href="#">LVDT/RVDT-Digital</a>	16-Bit resolution; 4 Ch. (Measurement)
<a href="#">Discrete</a>	0 to 60 VDC; Sink, source or push/pull; up to 24 Ch	<a href="#">Digital-Synchro/Resolver</a>	16-Bit; Up to 3 VA; 1-3 Ch. (Simulation)
<a href="#">Isolated Discrete</a>	0 to ±80 VAC or VDC; 16 Ch	<a href="#">Digital-LVDT/RVDT</a>	16-Bit; Up to 3 VA; 1-3 Ch (Simulation)
<a href="#">Relay</a>	SPDT; 4 Ch	<a href="#">AC Reference</a>	2 to 115 V <sub>RMS</sub> ; Up to 6 VA; 1 Ch
<a href="#">TTL</a>	0 to 5.5 VDC; 24 Ch	<a href="#">RTD</a>	16-Bit; 2, 3 or 4-wire; 8 Ch
<a href="#">Differential Transceiver</a>	Up to ±12V; 422/485 Pulse Gen/Meas; 16 Ch	<a href="#">Thermocouple</a>	J, K, T, E, R, S, B, N; 4 Ch
Communications		<a href="#">Strain Gage</a>	16-Bit; 4 Ch
<a href="#">MIL-STD-1553</a>	Quad Ch Dual Redundant; Transformer or Direct		
<a href="#">RS-232/422/423/485</a>	4 Ch		
<a href="#">ARINC 429/575</a>	12 Ch		
<a href="#">CANBus</a>	8 Ch		
<a href="#">Ethernet Switch*</a>	12 Ports; Layer 2/3 Management		

\*Occupies 2 slots

### Architected for Versatility

NAI's Configurable Open System Architecture™ (COSA®) offers a choice of over 70 smart I/O, communications, or Ethernet switch functions, providing the highest packaging density and greatest flexibility of any multifunction I/O board in the industry. Preexisting, fully-tested functions can be combined in an unlimited number of ways quickly and easily.

### Software Support

Software Support Kits (SSKs) for multiple operating systems are supplied free of charge, with source code and board-specific library I/O APIs, to facilitate system integration. Each I/O function has dedicated processing, unburdening the system SBC from unnecessary data management overhead.

### Background Built-In-Test (BIT)

BIT continuously monitors the status of all I/O during normal operations and is totally transparent to the user. SBC resources are not consumed while executing BIT routines. This simplifies maintenance, assures operational readiness, reduces life-cycle costs and— *keeps your systems mission ready.*

### One-Source Efficiencies

Eliminate man-months of integration with a configured, field-proven system from NAI. Specification to deployment is a seamless experience as all design, state-of-the-art manufacturing, assembly and test are performed— by one trusted source. All facilities are located in the U.S. and optimized for high-mix/low volume production runs and extended lifecycle support.

### Product Lifecycle Management

From design-in to production, and beyond, NAI's product lifecycle management strategy ensures the long-term availability of COTS products through technology refresh, configuration management and obsolescence component purchase and storage.

*Specifications are subject to change without notice. All product and company names are trademarks or registered trademarks of their respective holders.*



Made in the USA  
Certified Small Business